



ARRI

Getting the Most from Your New ARRI Kit

ARRI Lighting Handbook

by Bill Holshevnikoff

ARRI Lighting Handbook

Fourth Edition Handbook Images & Text © 2016 by
Bill Holshevnikoff

Handbook Designed & Produced by
Spencer Nilsen (www.illuminastudios.com)
and Bill Holshevnikoff
(www.videolightingtechniques.com,
www.poweroflighting.com)

Producer - video production
Christian Burton

Cover Image
Lindsay Elston

ARRI Inc.
617 Route 303, Blauvelt, NY 10913
Tel: +1 845 353 1400 Fax: +1 845 425 1250

600 North Victory Blvd., Burbank, CA 91502
Tel: +1 818 841 7070 Fax: +1 818 848 4028

lighting-info@arri.com
www.arri.com

Please go to <http://www.arri.com/goto/lighting/tools>
for online version of the handbook and more
materials.

Table of Contents

Section 1 - Lighting Theories & Techniques	4		
Introduction	4	Shadow	16
Choosing a Light Source	4	Shadow Edge Transfer	17
Light Quality	5	Specular Edge Transfer	17
Hard vs. Soft Light	7	Rule of Thumb	17
Light Source Intensity	9	Section 3 - New Lighting Technologies	18
A Note on Color	10	HMI® Technology	18
Section 2 - Basic Definitions	12	125 PocketPAR	19
Key Light	12	200 & 400 PocketPARs	19
Fill Light	13	LED Technology	20
Separation (Hair) Light	14	The L-Series LED Fresnels	21
Background Light	15	SkyPanel	22
Elements of 3-Dimensional Contrast	16	Section 4 - Lighting Showcase	24
Diffused Value	16	Section 5 - Resources & Contacts	50
Specular Highlight	16	Section 6 - Notes	54

Lighting Theories & Techniques

Introduction

There have been dozens of books throughout the past decades that have discussed "standard" lighting setups for interviews, talk shows, dramas and countless other productions. This handbook is designed to help you create the best possible images with your new ARRI Lighting Kit, using these tools when lighting location or studio productions.



ARRILITE Open-Face

Choosing a Light Source

The original ARRI Kits contained a variety of lighting fixtures. The two basic types of instruments were the open-faced instrument and the Fresnel-lensed instrument - all tungsten-based lights. Both types of light sources are still available and provide a focusable, even beam field of light that can be used to create a wide variety of light qualities and moods for your productions.

But times have changed and the ARRI Lighting Kit now offers a full line of LED fixtures that include Fresnels and soft lights, both of which can produce an enormous range of color.



ARRI L7-C LED Fresnel

Light Quality

Light quality can be characterized by how “hard” or “soft” the shadow produced by an instrument appears. The quality of light produced by an instrument is determined by the physical size (not the intensity) of the light source. In general, the larger, more diffused the light source, the softer the light quality. Typically, a diffusion material, such as frost or silk, might be placed in front of a lighting instrument to increase the working (physical) size of a light source.



ARRILITE with Frost

When light transmits through diffusion material, the illuminated diffusion material then becomes the acting light source. A sharp, well-defined shadow edge (hard light), like that created by the sun, is most often produced by a small light source, such as one of the instruments contained in this kit. A softer, less defined shadow edge (soft light)



**ARRILITE with
Chimera Lightbank**

Light Quality continued

like that created by a cloudy day, is produced by a larger, more diffused light source, such as a Lightbank (available with some ARRI Kits). If you do not have a Lightbank, there are many other ways to create softer light qualities with the instruments contained in this kit. Attaching frost to the barndoors will soften the light quality slightly. Placing a large diffusion panel (silk) in front of the source, or bouncing the light off of a white wall, ceiling or

white card, will produce a dramatically softer light quality. Again, the physical size of the light source is directly related to the quality of light produced. So, ideally, one should consider the appropriate light quality for a shot or scene prior to setting up the lighting. For example, hard light may not be considered a natural light quality for many interior scenes (such as an office with four white walls and overhead fluorescent lighting).



Hard Light



Soft Light

Hard vs. Soft Light

There is no rule as to when to use hard or soft light. Creating a particular light quality is subjective and there is no correct or incorrect method. There are, however, characteristics that are inherent to both hard and soft light, and one must constantly weigh the pros and cons of each prior to lighting a scene. In general, hard light is easily controlled through the use of barndoors on the fixture, and it can be used to produce dramatic shadows and attractive



ARRILITE bouncing off of Foam Core Board

lighting effects for film or video. When lighting people for interviews with hard light, one must carefully consider the placement of the light source in order to produce appealing results on camera. An ill-placed Fresnel or open-faced instrument can produce unkind results on even the most photogenic persons.

ARRI Fresnel-lensed lights produce an extremely even field of light, and are the most popular instrument choice when hard lighting is required for studio and location work.

While ARRILITES also produce an even beam field, these instruments generally are not used to light people directly. The ARRILITE instrument is most often used to create a fill light source, by bouncing light off of walls, ceilings or bounce boards (on location); to use with diffusion frost or behind a Lightbank; or to light background areas.

Hard vs. Soft Light continued

When used as a direct source (no diffusion), the glass lens on a Fresnel instrument produces a more pleasing quality of light than an open-faced instrument.

The use of softer light sources can be more forgiving when lighting people, but softer, diffused sources can be much more difficult to control. Diffused light disperses in many directions, and although the light quality may be desirable for a particular shot or scene, the uncontrolled spill light from a diffused source can ruin even the best of shots. Much of lighting has to do with directing the viewer's eye around the frame, and when spill light from your main light sources contaminates the background of your shot, the lighting can appear haphazard and lose visual impact. Once again, careful consideration of your light placement will dramatically improve the results.

When working with a Lightbank, control of the diffused light can be achieved with a product called a Soft Egg Crate (by LightTools and DoPChoice). This product is a collapsible fabric egg crate that can be quickly attached to the front of a Lightbank. The use of an egg crate on a Lightbank provides the user with instant control of spill light with little light loss.

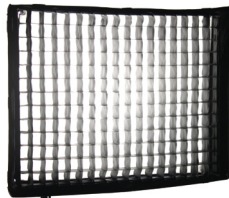

**Soft Egg Crate
on Lightbank**

Light Source Intensity

The intensity of the light source you choose for a shot is an important decision. Brighter is not necessarily better. Depth-of-Field (f-stop = depth of focus) and f-stop selection with your camera should be a conscious decision each time you begin lighting a shot.

Many of the newest digital cameras are extremely light sensitive. Lighting a scene with too much light forces you to close down the iris to a deeper f-stop (f8 – f11) to properly expose the scene. This creates a very deep focus range (depth of field) in your shot. Using smaller lighting instruments and less light allows you to expose your scene at an iris setting of perhaps f2.0 or f2.8. Shooting with an open iris (aperture) creates a shallower depth-of-field and allows you to utilize selective focus as a creative tool in image-making.

Additionally, you can down-lamp your ARRI tungsten instruments to use lower wattage bulbs. For example, the ARRI 650 Fresnel also can use a 500W or 300W lamp. This provides you with the wider beam field of the larger Fresnel while still working with lower light output. When working with ARRI LED instruments, the option of dimming the instrument is a simple and effective way to work at much lower light levels. Shooting at lower light levels with the newer cameras allows the use of instruments as small as a 150W ARRI Fresnel. Used in conjunction with proper lighting techniques, shooting with a shallow depth-of-field can enable you to create more of a film look when shooting with your digital camera.

A Note on Color

The color of the tungsten lighting fixtures in your ARRI Kit is rated at 3,200 degrees on the Kelvin temperature scale. Although the light from these instruments may appear as white light on video or film, it is actually a very warm-colored light relative to the color of daylight. Choosing a tungsten film stock or setting your digital camera for tungsten (3,200K) will give you proper color rendering when lighting with these tungsten lighting fixtures. Be careful when white balancing your camera that you are balancing your camera for the light in your subject area. Proper white balance will ensure accurate skin tones in your video productions. Sometimes you may be shooting in an area with existing ambient light and the color of that ambient light may differ dramatically from the color of light generated by the tungsten lighting instruments in your ARRI Kit. The color of fluorescent light in

office areas, commercial light in retail or industrial settings and ambient daylight all differ greatly from the color of light created by your tungsten lights. In these cases, it may be necessary to color correct your lighting instruments to match the color of the ambient light in your scene.

Your ARRI lights can be color corrected through the use of color correction gels which can be attached directly to the barndoors of your instruments. Just be aware of the fact that using gels on your lights



can greatly reduce the output of light (i.e. full CTB/ daylight correction gel can reduce output by as much as 85%). Also, gels can burn when set too close to the lamp or lens on your lights. Careful use of correction gels can help you to manipulate and match the color of the existing light in your scene. The use of ARRI LED lighting instruments can make the process of color correcting much easier. ARRI's L-Series and SkyPanel instruments are color tunable from 2,800 - 10,000 degrees Kelvin, providing you with complete control of your color temperatures for any scene.

Additionally, you might consider supplementing your lighting package with additional ARRI lighting instruments designed specifically for production use in daylight settings. ARRI HMI (daylight balanced) instruments are used daily in motion picture and video production work around the world. See your local ARRI equipment dealer or visit the ARRI website for more information. www.arri.com

Basic Definitions

The Four Primary Light Sources: Key, Fill, Separation & Background

In this section, the “lighting evolution” of images shows the single effect of each of these four light sources in a talking head shot.

Key Light

The key light is the primary light source for the subject area of the image. The key light is the main source of illumination and often establishes a light quality, whether hard or soft, for the shot or scene. When lighting people for on-camera interviews, the object of the key light is to illuminate the person in an attractive manner and reveal the shape of the person’s face through shadow form (modeling). An ARRI Fresnel is often the choice for a key light source due to the ease of use and light control. Lightbanks also are a popular key light source for interviews.

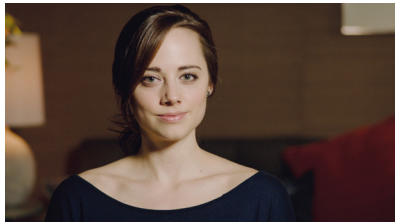

Key Light only

Position of the key light can range from directly above the camera lens to completely behind the subject, depending upon the desired results. Seeing the effects of the key light shadows on the subject’s face will help you determine the best height and location for this light. When lighting for multiple cameras, it is usually best to place the key lights for optimal results

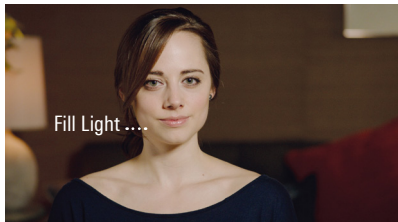

Key & Fill Light

on the close-up camera positions for each subject. Regardless of the quality of light you choose, the light from the key source should be confined to the subject area if you hope to achieve a dramatic lighting effect for the image. If a less dramatic effect is desired, the spill light from the key source can be allowed to illuminate the background area as well.

Fill Light

The fill light is an additional light source designed to fill in the shadow areas created by the key source. Ideally, the fill light source is a larger, diffused soft light source that will fill in the shadow area to the desired density (light level) without producing a second, opposing shadow on the subject(s). Think of your fill lighting as ambient light for the shot or scene, and as your visual mood indicator. The less fill light, the more dramatic the lighting. Regardless of whether your key source is hard or soft light, using a hard light source for a fill light can create an unnatural double-shadow effect on the subjects. Use of a large silk, a Lightbank, dense white diffusion material on the barndoors, or bouncing the light off of a white surface (wall, bounce board, etc.) can produce a natural and effective fill

The Four Primary Light Sources: Key, Fill, Separation & Background continued

light source. When shooting only a close-up of a single person, often the spill light from your key source can be directed at a large, white bounce card for a soft, shadowless fill light (see examples). The position of the fill light can vary greatly, but normally fill light sources are set either near the camera lens or at a position opposite the key light source.

Separation Light (Hair Light)

The separation light, or hair light, is designed to help visually separate the subject(s) from the background. A separation light is not always necessary, but without the use of this light, it is possible that the subject could blend with the background. Use of a separation light also helps to bring out color and texture in the subject's hair. Brightness of the separation light can equal the brightness of the key light source, but the intensity

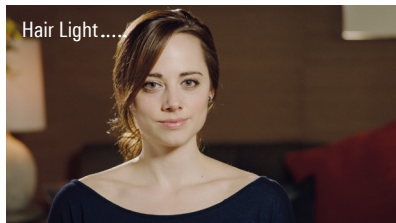

Key, Fill & Hair Lights

and placement should be determined by the color and texture of the subject's hair and the placement of any practical sources (windows, lamps, etc.) in the scene. Position of this source can range from directly behind and above the subject to just outside of the frame line to create a side rim-light. As is true with almost all light placements, the effect of the separation light is dramatically altered by its position. Experiment with different light qualities and placements to find your own favorite look.

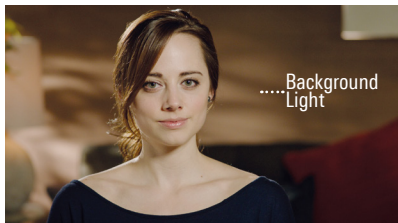

Key, Fill, Hair & Background Lights

Background Light

The background light can be the first or final light to be set for a scene or shot, depending upon the importance of the background lighting in the scene and your lighting style. If careful consideration has been given to the control of spill light in the subject area, the effect of your background light can be quite dramatic. The addition of a background light also can help to add texture, color and/or added separation for the subject(s) from the background.

Direction of the background light also can help to support key light direction and motivation (i.e. light from a window, etc.). Both Fresnels, ARRILITES and any of the LED fixtures can be used effectively to light background areas.

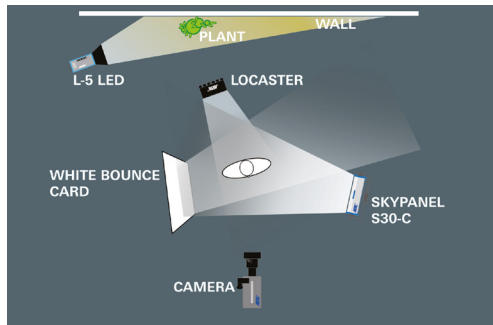

Elements of 3-Dimensional Contrast

Artists of all types are constantly working to create a 3-dimensional image on a 2-dimensional plane (motion picture screen, television screen, paper, etc.). The following information will help you better identify and manipulate the separate components of reflected light.

Theory of 3-Dimensional Contrast

The theory states that a single light source directed at a single object of a single density normally will produce three separate densities: the diffused value, the specular highlight and the shadow. The presence of these three densities can reveal shape, form, texture, density and depth.

Diffused Value

The true tone or natural brightness of an object. Accurate reproduction of the diffused value often determines a proper exposure. The diffused is a constant, objective value, while the shadow and specular are variable and subjective.

Specular Highlight

The mirrored image of a light source on an object. The specular highlight is always brighter than the true tone of the object. A properly placed specular highlight will reveal shape and texture on an object.

Shadow

The area on a 3-D object that receives no illumination from the primary light source. The shadow is always lower in brightness than the true tone of the object. A properly placed shadow will reveal shape and form on an object.

Shadow Edge Transfer

The area of transition between the diffused value and the shadow. It is the primary indicator to determine the quality of light produced, i.e. hard or soft light.

Specular Edge Transfer

The area of transition between the diffused value and the specular highlight. The specular edge transfer usually defines the surface texture of an object. The smoother the surface, the harder the edge transfer.

Rule of Thumb

The larger the light source, the softer the light quality.

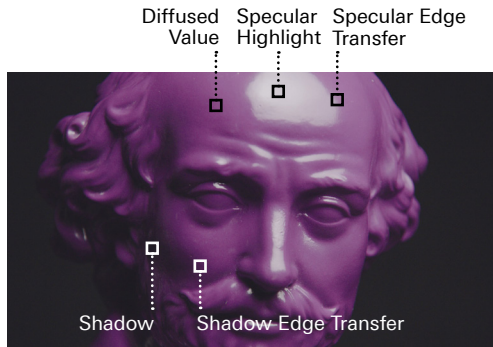

New Lighting Technologies

Lighting instruments for the majority of film and television productions have remained basically the same for many years. Fresnel-lensed lights and open-faced instruments have been the backbone of the craft since its inception. Studio soft lights were also an important addition to the lighting industry. Over the past 30 years, HMI lights and fluorescent instruments have made their impact on filmmaking and television, and have changed the ways of our business. Most recently, LED fixtures are providing another new lighting tool for the image making professional. The latest technologies used in lighting instrument design also have allowed for the development of some new tools -- high-output, compact HMI and LED instruments from ARRI Lighting. These new lighting fixtures are creating yet another new chapter in ARRI's legacy in the film industry.

This section is designed to help you to better understand HMI and LED technology and the ARRI Lighting fixtures available for you and your production needs.

HMI® Technology

The HMI lamp uses mercury vapor mixed with metal halides in a quartz-glass envelope, with two tungsten-coated electrodes of medium arc separation. The light from an HMI source approximates the look and color of raw sunlight. Unlike traditional tungsten lighting instruments using incandescent bulbs, HMIs use ballasts to regulate the electrical supply to the lamp head, and power is fed via a head-feeder cable. ARRI Lighting's HMI lights are high-output sources that produce a daylight spectrum with a color temperature of approximately 5600 degrees Kelvin, and currently the instruments range from 125 watts to 18,000 watts.

This section of the booklet will explain the line of compact ARRI HMI PocketPARs and the kits available for use on-location or in the studio

125 PocketPAR

ARRI's smallest, most compact HMI, the 125-watt PocketPAR is ideal for close-ups or set-ups where space is limited. The 125 PocketPAR offers superb punch and is invaluable for both direct lighting and for use as an indirect light source. A wide variety of accessories are available for innumerable lighting design applications.



ARRI 125 PocketPAR



ARRI 200 PocketPAR



ARRI 400 PocketPAR

200 & 400 PocketPAR

The low-heat 200- and 400-watt PocketPARs are perfect for small spaces, close-up work or more difficult confined set-ups. Both fixtures offer superb punch and are invaluable for direct lighting in daylight environments, can be used with a Chimera Lightbank or Lanterns, or used as bounced fill light. ARRI's custom-designed dichroic, glass faceted reflector and matching spread lenses ensure maximum beam control in all situations. A wide variety of accessories are available for innumerable lighting design applications.

New Lighting Technologies continued

LED Technology

There are many advantages to using LEDs over incandescent light sources, including lower energy consumption, longer lifetime, smaller size and greater durability and reliability. However, they require precise heat management and the color rendering index (CRI) must be considered in fixtures used in production. ARRI's LED Caster Series are high output, low heat, low power consumption lighting units with a tuneable white light source. The special optical design provides single shadow rendering and adjustments over a range of color temperatures. The ARRI Caster Series offers a Color Rendering Index (CRI) of 90, ensuring more vivid and lifelike colors on digital and film media. There are two versions in the LED Caster Series, the LoCaster and the BroadCaster. Each LED instrument offers high output, yet very low power consumption while in a housing that only weighs 2lbs. Both units utilize the same optical principles and the same

housing, yet consume only 35W of power. On the LoCaster, power, dimming and the color temperature may be manually adjusted with onboard controllers. This unit is adjustable in color temperature from 2800 Kelvin to 6500 Kelvin. The LoCaster or BroadCaster can be powered by the use of several AC Power Supply options or any DC source from 11-36V (20-36V for optimal performance). The advantage of the BroadCaster is that multiple units can be assigned for remote control via a DMX protocol and console. The optional intensifier is a valuable accessory which doubles the light output while creating a tighter beam



ARRI LoCaster

of light (to 33°). Both the LoCaster and BroadCaster may be orientated in either horizontal or vertical mode. Also available are 'Hybrid' kits in various configurations which combine the LoCaster LED fixtures with our proven small tungsten Fresnels.



ARRI Hybrid Kit

The L-Series LED Fresnels

The ARRI L-Series is an LED Fresnel fixture so close to its conventional counterpart in function and performance that it creates a previously unattainable

opportunity: like-for-like replacement of traditional Fresnels with LED-based units.

At the heart of the L-Series are a few core concepts: tuneability, color fidelity, high build quality and ease of use. Three simple knobs permit the brightness, color temperature and green/magenta point to be fine-tuned, while a focus knob on the side of each fixture allows for smooth adjustment of the beam spread, just like conventional sources.

The L-Series is the first LED fixture to truly incorporate the Fresnel characteristics of continuous focusability from spot to flood and a smooth, homogenous



ARRI L5 LED

New Lighting Technologies continued

light field. The L-Series takes full advantage of LED technology and allows for complete control over the color and intensity of light. Light emitted from the L7 is specifically calibrated for optimal reproduction on broadcast and digital cinema cameras, ensuring pleasing skin tones and vividly rendered colors. Constructed to be robust and ergonomic, the L7 meets the quality and design standard for which ARRI is known. Encompassing multiple power classes, the L-Series offers solutions for almost any application, from large television studios to small



ARRI L7 LED

interview setups and everything in-between. The L5, L7 and L10 lampheads, which respectively feature 5", 7" and 10" Fresnel-like lenses, are available in tuneable tungsten, tuneable daylight or fully color controllable versions.

The SkyPanel

The new ARRI SkyPanel is an exceptionally versatile LED soft light – compact, fully tuneable and delivering light of unsurpassed power and quality. Because different application areas call for different lighting needs, SkyPanel has been designed as a series of fixtures. The S60 is the mid-range model and the S30 is the smaller, more portable version available in ARRI LED kits. SkyPanel 'C' (Color) versions have the ability to adjust the correlated color temperature anywhere between 2,800K and 10,000K, with excellent color rendition over the entire range. Full plus and minus green correction can be achieved with the simple

turn of a knob, and in addition to CCT control, vivid color selection and saturation adjustment is also possible. The shadows are soft in nature and do not exhibit multiple edges or strange colors, making SkyPanel one of the best LED soft lights for shadow rendition on the market. The SkyPanel user interface is designed to be incredibly easy to use, but also to make a wide range of controls available to the user, all at the same time. With three simple knobs, the color temperature, green/magenta point, intensity, hue and saturation can be adjusted instantly. People who have never used the light before find the interface effective and intuitive. In addition to the on-board controls, all functions can be remotely adjusted via DMX or LAN network connections.



ARRI SkyPanel S30-C



ARRI SkyPanel S60-C

Lighting Showcase



The following images and diagrams provide you with basic lighting setups that you can achieve with your ARRI Lighting Kit for a variety of studio and location productions.

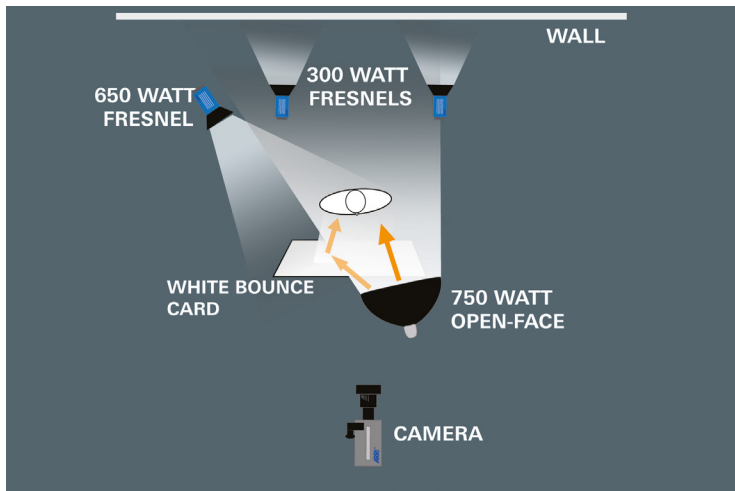

The tools in an ARRI Lighting Kit can provide for so many different possibilities. This image of Lindsay uses a mix of soft and hard light to create a great look for commercial or corporate productions.

Technical Data:

- 1 - ARRI 650 watt Fresnel
- 1 - 750 watt Open Face
- 1 - Chimera LightBank
- 2 - ARRI 300 watt Fresnels
- 1 - White Bounce Card



This dramatic interview setup with Leo was accomplished with only 2 lights - and the use of a DoPChoice SnapGrid on the SkyPanel S30-C to control the spill light from the white walls in the background.

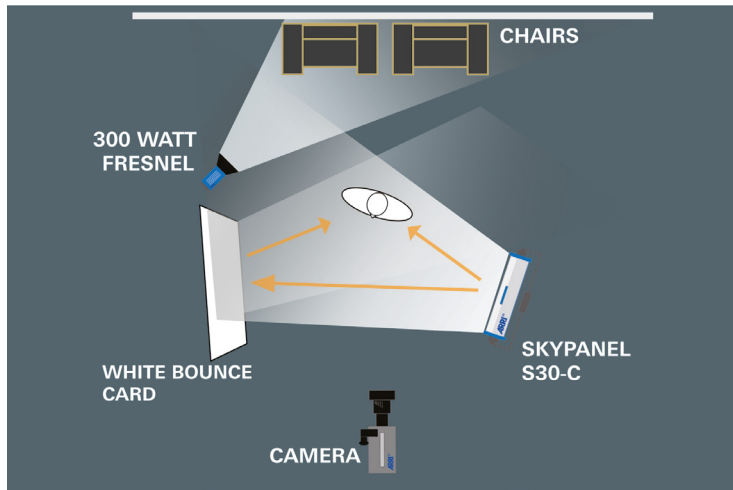

Technical Data:

- 1 - ARRI SkyPanel S30-C
- 1 - ARRI 300 watt Fresnel
- 1 - White Bounce Card
- 1 - DoPChoice SnapGrid



Working in available light can offer some beautiful opportunities, but often the subject needs a touch of light for their face and eyes. This image of Carrie works well with the use of two ARRI LoCasters side-by-side as a daylight-balanced fill light source.

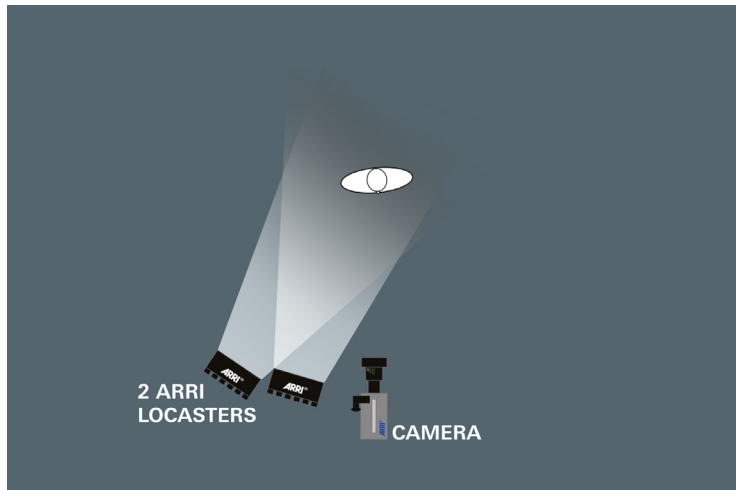

Technical Data:
2 - ARRI LoCasters

Section 4 - Lighting Showcase

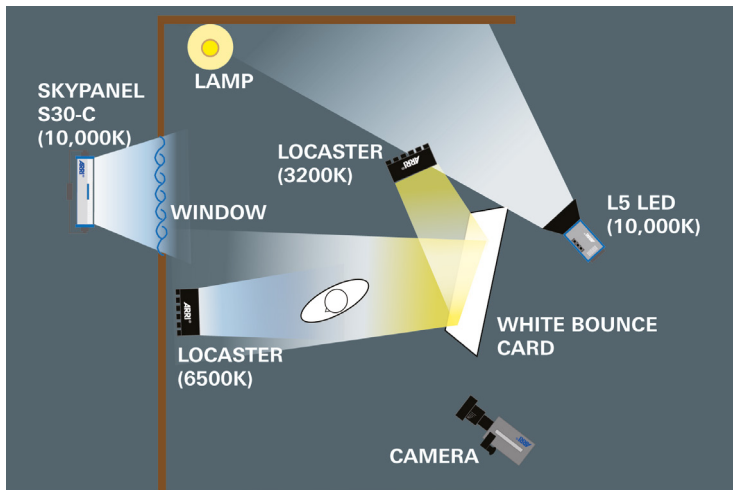

This cozy "moonlit" image was created in-studio with an all-LED setup. A SkyPanel S30-C and an L5 provide the moonlight effects on the set, while 2 LoCasters set at different color temperatures illuminate Ali with a convincing evening glow.

**Technical Data:**

- 2 - ARRI LoCasters
- 1 - ARRI SkyPanel S30-C
- 1 - ARRI L5 LED
- 1 - White Bounce Card



Reality shows and interviews can be done in so many ways. This image of Jamar shows how to use hard light effectively - even with darker skin tones.

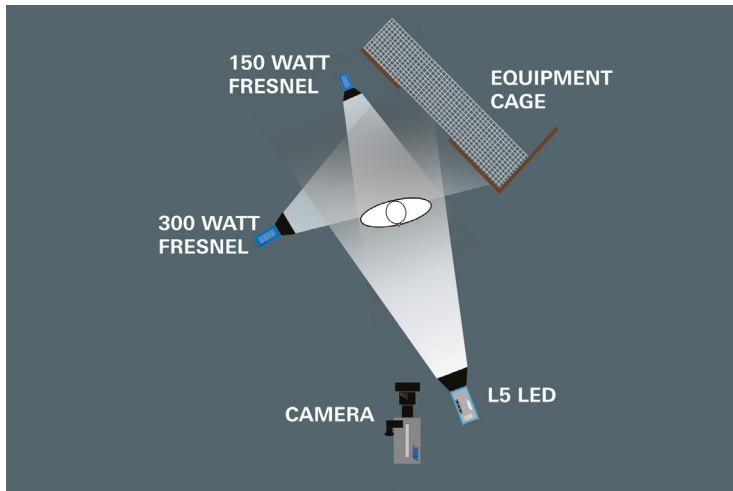

Technical Data:

- 1 - ARRI 300W Fresnel
- 1 - ARRI150W Fresnel
- 1 - ARRI L5 LED

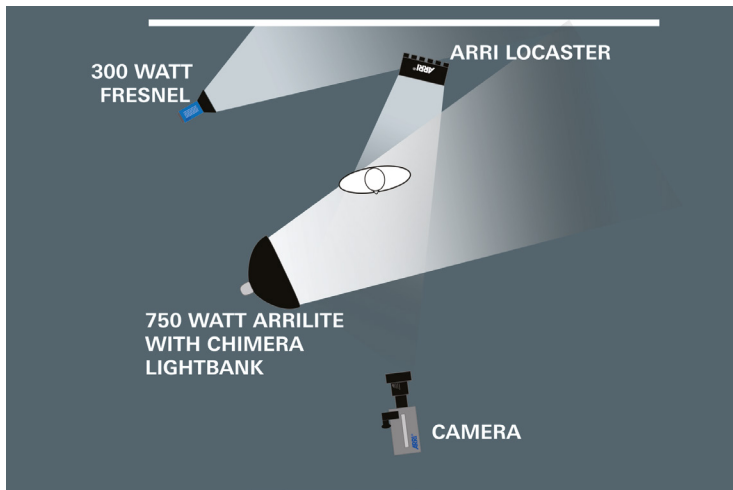

The high-key interview look with a white background is very popular today. This simple setup uses the soft light from a Chimera Lightbank, an LED kicker on Christian's cheek, and a 300W tungsten Fresnel on the background for a clean, effective interview look.

**Technical Data:**

- 1 - ARRI 300W Fresnel
- 1 - ARRI LoCaster
- 1 - 750W ARRILITE
- 1 - Chimera Lightbank

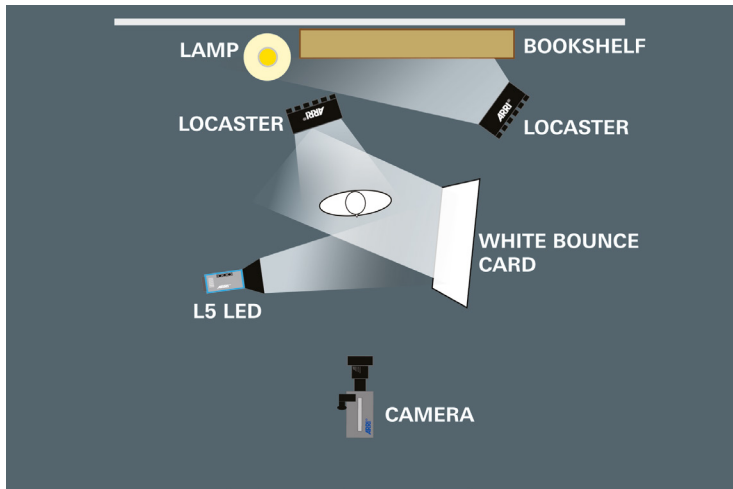

Lighting faces is a craft that requires an attention to detail for each person you light. This setup uses the L5 LED Fresnel, but the light is bounced off of a white card for a soft, natural-looking key light on the subject.

**Technical Data:**

- 1 - ARRI L5 LED Fresnel
- 2 - ARRI LoCasters
- 1 - White Bounce Card



Music videos and commercial productions can demand high production values executed quickly. This simple 2-light setup with Jamar displays how to use the amazing range of color from the SkyPanel S30-C to dial-in your look.

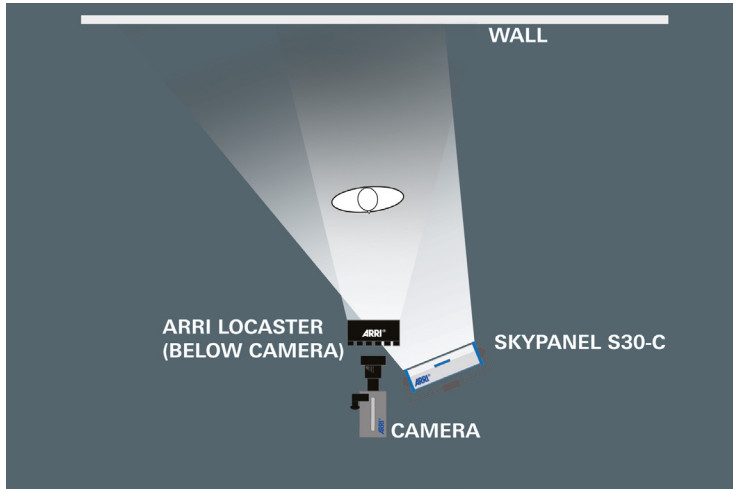

Technical Data:

- 1 - ARRI LoCasters
- 1 - ARRI SkyPanel S30-C

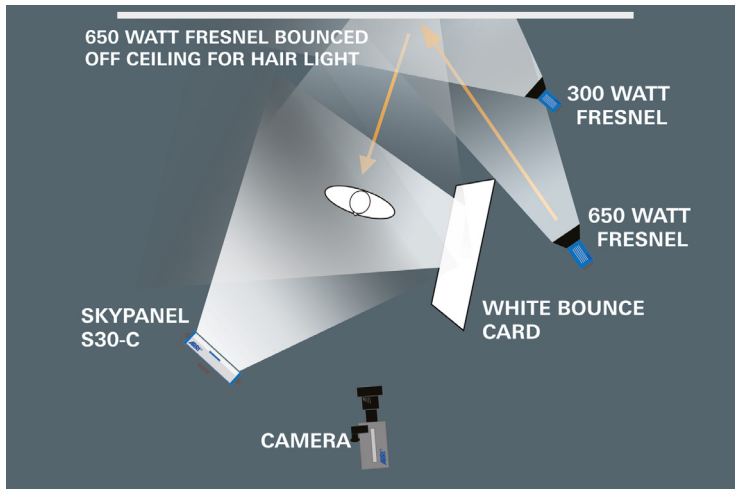

Locations like corporate offices can be uninteresting if you use the available lighting. This image of Ali utilizes both LED and tungsten lighting for a dramatic interview look.

**Technical Data:**

- 1 - ARRI 650W Fresnel
- 1 - ARRI 300W Fresnel
- 1 - ARRI SkyPanel S30-C
- 1 - White Bounce Card

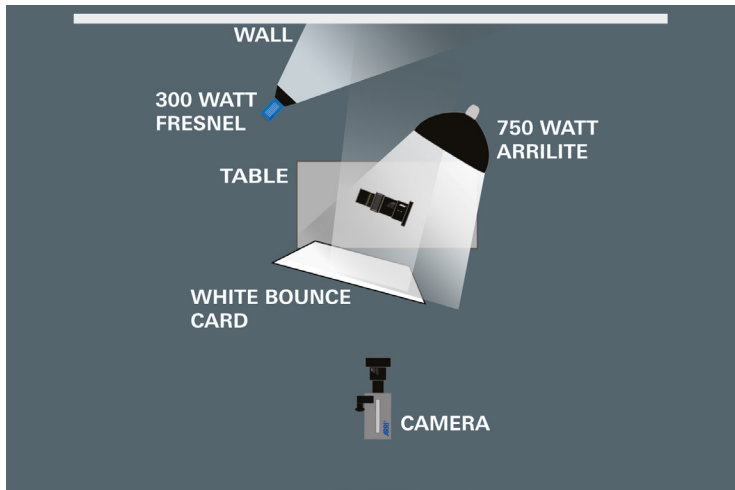

Highly reflective and black products can be a difficult lighting challenge. This image shows how the use of the Chimera Lightbank and a white bounce card can help you to create stunning product shots.

**Technical Data:**

- 1 - 750W ARRILITE
- 1 - ARRI 300W Fresnel
- 1 - Chimera Lightbank
- 1 - White Bounce Card

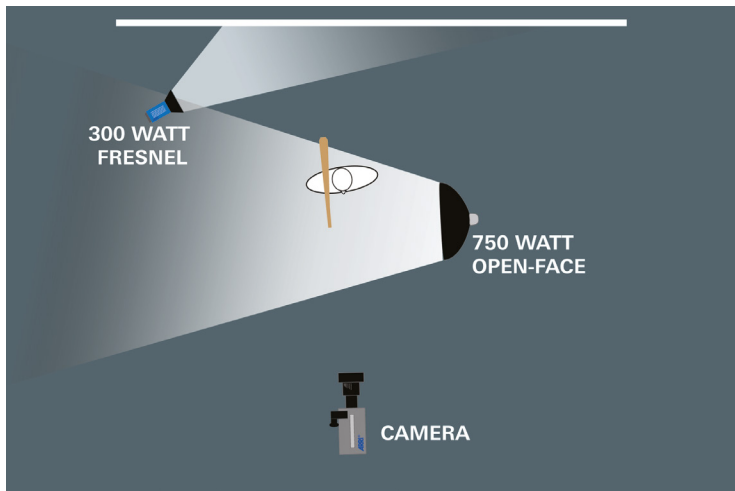

Lighting subjects who are wearing hats with brims can be challenging. The use of a large, soft source allows you to work with almost any type of hat and still create a great look. This image of Christian was created with only 2 lights.

**Technical Data:**

- 1 - 750W ARRILITE
- 1 - ARRI 300W Fresnel
- 1 - Chimera Lightbank

Section 4 - Lighting Showcase

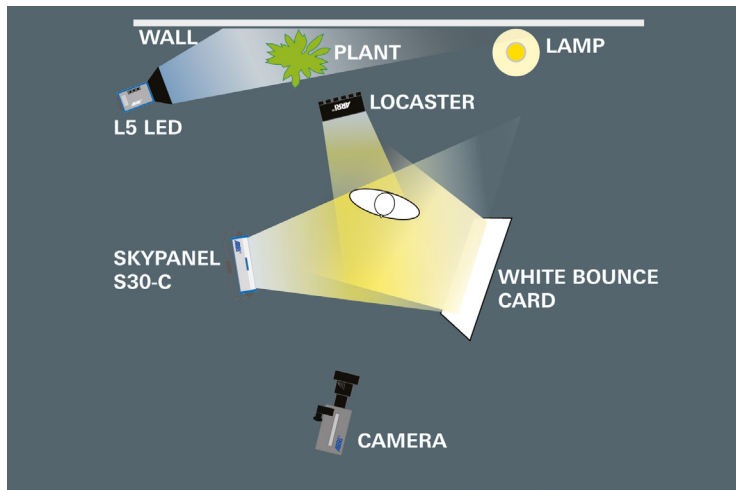

ARRI's LED instruments allow you to create with color. This image of Magalie feels like an evening interview in a home, but it was actually created on a studio set.

**Technical Data:**

- 1 - ARRI L5 LED
- 1 - ARRI LoCaster
- 1 - ARRI SkyPanel S30-C
- 1 - White Bounce Card



This interview with Paula utilizes an L5 LED Fresnel to light both the subject and the background wall. Whether in-studio or on-location, this simple lighting setup works for both over-the-shoulder and close-up shots from the same camera angle.

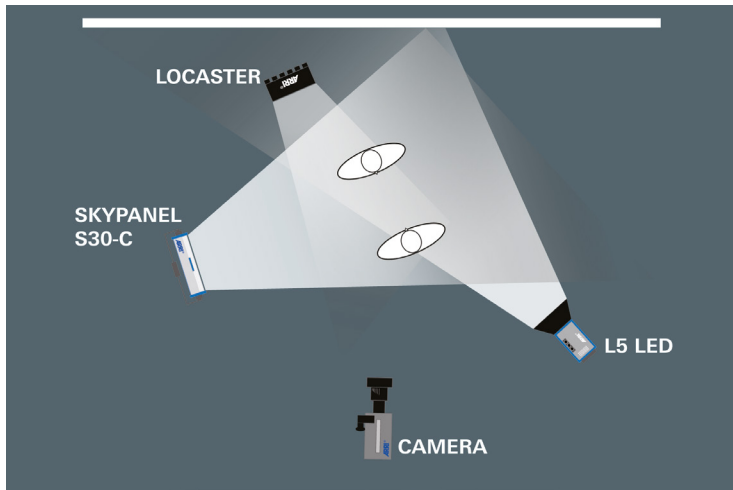

Technical Data:

1 - ARRI LoCaster

1 - ARRI SkyPanel S30-C

1 - ARRI L5 LED

Resources and Contacts

ARRI Sales Contacts

Europe, Middle East, Africa, India

Arnold & Richter Cine Technik

GmbH & Co. Betriebs KG (Sales & Service)

Ernst-Augustin-Strasse 12, 12489 Berlin, Germany

sales-lighting@arri.de

Tel: +49 (0)30 678 233 0, Fax: +49 (0)30 678 233 99

ARRI Italia S.r.l. (Sales & Service)

Viale Edison 318,

20099 Sesto San Giovanni (Milan), Italy

info@arri.it

Tel: +39 02 262 271 75, Fax: +39 02 242 1692

Americas

ARRI Inc./West Coast & Mexico (Sales & Service)
600 North Victory Blvd., Burbank, CA 91502-1639, USA
info@arri.com
Tel: +1 818 841 7070, Fax: +1 818 848 4028

ARRI Inc. / East Coast (Sales & Service)
617 Route 303, Blauvelt, NY 10913-1109, USA
info@arri.com
Tel: +1 845 353 1400, Fax: +1 845 425 1250

ARRI Inc. / Central & Southern America (Sales)
2385 Stirling Road, Ford Lauderdale, FL 33312, USA
ventas@arri.com
Tel: +1 954 322 4545, Fax: +1 954 322 4188

ARRI Canada Limited (Sales & Service)
1200 Aerowood Drive,
Unit 29 Mississauga, Ontario L4W 2S7
info@arri.com
Tel: +1 416 255 3335, Fax: +1 416 255 3399

Asia

ARRI Asia Limited (Sales & Service)
2801-2, Exchange Tower, 33 Wang Chiu Road,
Kowloon Bay, Hong Kong,
info@arriasia.hk
Tel : +852 2571 6288, Fax : +852 2875 9181

ARRI China (Beijing) Co. Ltd. (Sales & Service)
Chaowai SOHO Tower C, 6/F, 0628/0656
Chaowai Dajie Yi 6, Beijing, China
store@arri.cn
Tel : +86 10 59009680, Fax : +86 10 59009679

Australia / New Zealand

ARRI Australia Pty Ltd (Sales & Service)
Level 1, Unit 1, 706 Mowbray Road,
Lane Cove NSW 2066, Sydney, Australia
info@arri.com.au
Tel: +61 2 9855 4300, Fax: +61 2 9855 4301

ARRI Service Contacts

Zone	Availability	Service Center	E-Mail	Telephone Hotline
1	Monday – Thursday: 7:00 – 17:00 (CET) Friday: 7:00 – 15:00 (CET)	Stephanskirchen, Germany Arnold & Richter Cine Technik	service-lighting@arri.de	+49 (0)8036 3009 3009
2	Monday – Friday: 09:00 – 17:30 (EST)	New York, USA ARRI Inc. East Coast	service-lighting@arri.com	+1 845 353 1400
	Monday – Friday: 08:30 – 17:15 (PST)	Burbank, USA ARRI Inc. West Coast	service-lighting@arri.com	+1 818 841 7070
3	Monday – Friday: 09:00 – 18:00 (HKT)	Hong Kong, China ARRI Asia Limited	service@arriasia.hk	+852 2537 4266
	Monday – Friday: 09:00 – 18:00 (CST)	Beijing, China ARRI China (Beijing) Co. Ltd.	service@arri.cn	+86 5900 9680
	Monday – Friday: 08:00 – 17:00 (AEST)	Sydney, Australia ARRI Australia Pty Limited	service-lighting@arri.com.au	+61 2 9855 4305

This ARRI Lighting Handbook (Ident.-Nr.: L5.0010196) is published by Arnold & Richter Cine Technik, April 2016 © ARRI/2016. Technical data and offerings are subject to change without notice. All rights reserved. Without any warranty. Not binding 04/2016. ARRI is a registered trademark of Arnold & Richter Cine Technik GmbH & Co. Betriebs KG.

Zone 2 - Americas

Burbank ● New York ●

Zone 1 - EMEA

● Stephanskirchen

Zone 3 - Asia Pacific

● Beijing

● Hong Kong

● Sydney

www.arri.com

ARRI®